

General Description

The **αRD124A** consists of four independent, high gain, internally frequency compensated operational amplifiers which were designed specifically to operate from a single power supply over a wide range of voltages. Operation from split power supplies is also possible and the low power supply current drain is independent of the magnitude of the power supply voltage.

Application areas include transducer amplifiers, DC gain blocks and all the conventional op amp circuits which now can be more easily implemented in single power supply systems. The **αRD124A** can be directly operated off of the standard +5Vdc power supply voltage which is used in digital systems and will easily provide the required interface electronics without requiring the additional +15Vdc power supplies.

Features

- Available with Radiation Specification
 - Total Ionization Dose (TID) 300 krad(Si) (dose rate = 36 - 360 rads(Si)/h)
 - ELDRS Free 300 krad(Si)
 - Single event phenomenon (SEP):
- $\sigma_{\text{sat}} < 2.2e-3 \text{ cm}^2 \text{ at LET} = 62.5 \text{ MeV} \cdot \text{cm}^2/\text{mg}, \text{LET}_{\text{th}} > 1 \text{ MeV} \cdot \text{cm}^2/\text{mg}.$
- No SEDR was observed with a LET of 62.5 MeV.cm²/mg, Xenon heavy ion.
(The heavy ion trials are performed on qualification lots only).

- Internally Frequency Compensated for Unity Gain
- Large DC Voltage Gain 250 V/mV
- Wide Bandwidth (Unity Gain) 0.75 MHz
(Temperature Compensated)
- Wide Power Supply Range:
 - Single Supply 3V to 32V
 - Or Dual Supplies ±1.5V to ±16V
- Very Low Supply Current Drain (700 μA) – Essentially Independent of Supply Voltage
- Low Input Biasing Current 45 nA (Temperature Compensated)
- Low Input Offset Voltage 2 mV and Offset Current: 5 nA.
- Input Common-Mode Voltage Range Includes Ground
- Differential Input Voltage Range Equal to the Power Supply Voltage
- Large Output Voltage Swing 0V to V⁺ – 1.5V

Unique Characteristics

- In the Linear Mode, the Input Common-Mode Voltage Range Includes Ground and the Output Voltage can also Swing to Ground, even though Operated from Only a Single Power Supply Voltage
- The Unity Gain Cross Frequency is Temperature Compensated
- The Input Bias Current is also Temperature Compensated

Advantages

- Eliminates Need for Dual Supplies
- Four Internally Compensated Op Amps in a Single Package
- Allows Directly Sensing near GND and V_{OUT} also Goes to GND
- Compatible with all Forms of Logic
- Power Drain Suitable for Battery Operation

αRD124A Data Sheet

Ordering information

Table 1

Part	Temp. range, °C	Package	Package drawing	Burn-In case temp, °C	Burn-In time, hrs
αRD124A	-55 to +125	14-lead ceramic flatpack	Figure 3	+125	240

Pin Function Description

Figure 1

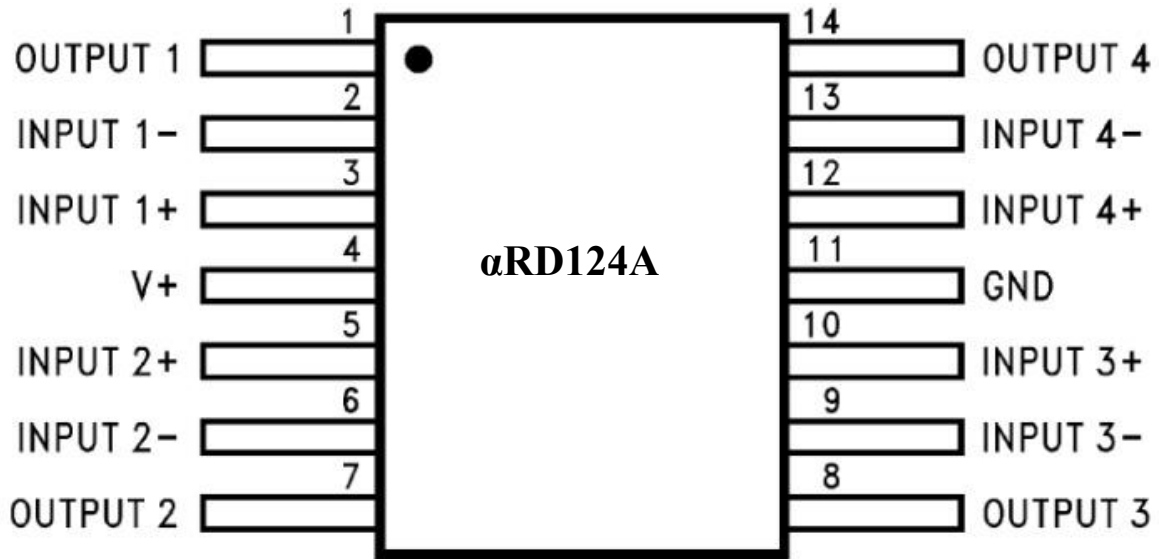

Functional Diagram

Figure 2

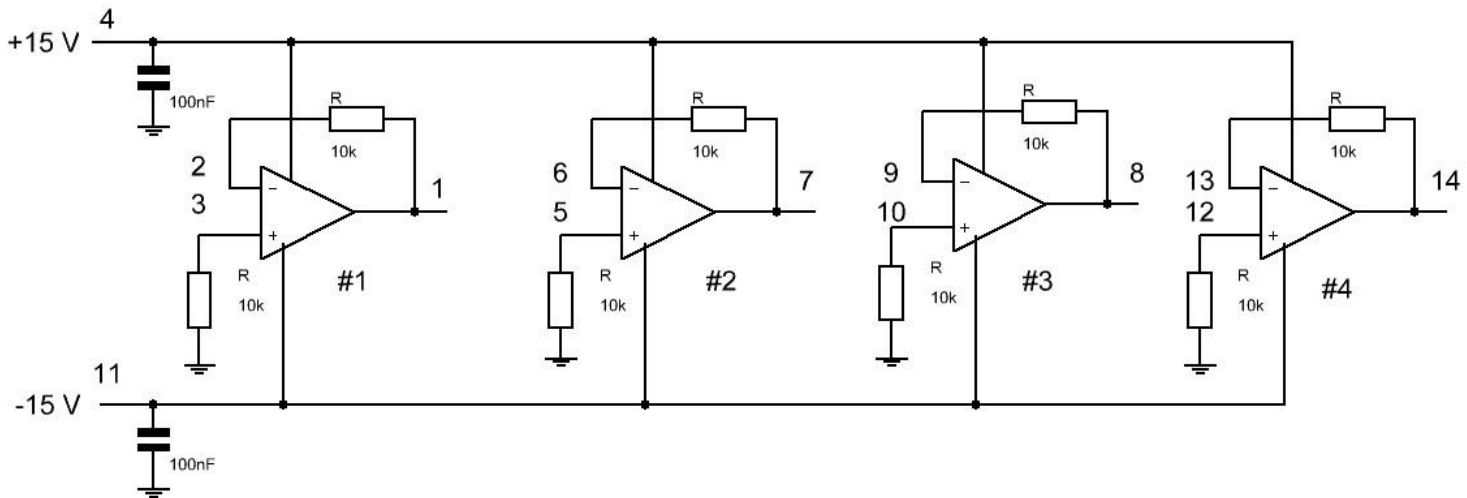

αRD124A Data Sheet

Absolute maximum ratings

Table 2

No	Characteristics	Symbol	Maximum ratings	Unit	Remarks
1	Supply Voltage	V _{CC}	32 or ±16	V	-
2	Differential Input Voltage	V _{ID}	32	V	-
3	Input Voltage		-0.3 to +32	V	(note 1)
4	Input Current (V _{IN} < -0.3V)	I _{IN}	50	mA	(note 2)
5	Power Dissipation	P _D	700	mW	-
6	Output Short-Circuit Duration (One Amplifier)	I _{os} (t)	Indefinite		(note 3)
7	Operating Temperature Range	T _{op}	-55 to +125	°C	-
8	Maximum Junction Temperature	T _j	+150	°C	-
9	Storage Temperature Range	T _{stg}	-65 to +150	°C	-
10	Lead Temperature (Soldering, 10 seconds)	T _{sol}	+260	°C	-
11	Thermal conductivity		18	W/mK	-
12	ESD Tolerance		250	V	(note 4)

Notes:

- (1) For supply voltages less than +32V, the absolute maximum input voltage is equal to supply voltage.
- (2) This input current will only exist when the voltage at any of the input leads is driven negative. It is due to the collector-base junction of the input PNP transistors becoming forward biased and thereby acting as input diode clamps. In addition to this diode action, there is also lateral NPN parasitic transistor action on the IC chip. This transistor action can cause the output voltages of the op amps to go to the V⁺ voltage level (or to ground for a large overdrive) for the time duration that an input is driven negative. This is not destructive and normal output states will re-establish when the input voltage, which was negative, again returns to a value greater than -0.3VDC (at 22±3°C).
- (3) Short circuits from the output to V_{CC} can cause excessive heating and eventual destruction. The maximum output current is approximately 20 mA, independent of the magnitude of +V_{CC}. At +V_{CC} > +15V, continuous short circuits can exceed the power dissipation ratings and cause eventual destruction.
- (4) Human body model, 1.5 kΩ in series with 100 pF.

αRD124A Data Sheet

Electrical DC characteristics within operating temperature range

Table 3
Notes (1) (2)

Parameter	Symbol	Conditions	T _A , °C	Limits		Units		
				Min	Max			
Input Offset Voltage	V _{IO}	+V _{CC} = 30V, -V _{CC} = Gnd, V _{CM} = +15V	+22 ±3	-2	2	mV		
			+125(+0-3)	-4	4			
			-55(+ 5-0)	-4	4			
				R, A (note 1)	+22 ±3	-2.5	2.5	
		+V _{CC} = 2V, -V _{CC} = -28V, V _{CM} = -13V	+22 ±3	-2	2	mV		
			+125(+0-3)	-4	4			
			-55(+ 5-0)	-4	4			
				R, A (note 1)	+22 ±3	-2.5	2.5	
		+V _{CC} = 5V, -V _{CC} = Gnd, V _{CM} = +1.4V	+22 ±3	-2	2	mV		
			+125(+0-3)	-4	4			
			-55(+ 5-0)	-4	4			
				R, A (note 1)	+22 ±3	-2.5	2.5	
		+V _{CC} = 2.5V, -V _{CC} = -2.5, V _{CM} = -1.1V	+22 ±3	-2	2	mV		
			+125(+0-3)	-4	4			
			-55(+ 5-0)	-4	4			
				R, A (note 1)	+22 ±3	-2.5	2.5	
Input Offset Current	I _{IO}	+V _{CC} = 30V, -V _{CC} = Gnd, V _{CM} = +15V	+22 ±3	-10	10	nA		
			+125(+0-3)	-10	10			
			-55(+ 5-0)	-30	30			
				R, A (note 1)	+22 ±3	-15	15	
		+V _{CC} = 2V, -V _{CC} = -28V, V _{CM} = -13V	+22 ±3	-10	10	nA		
			+125(+0-3)	-10	10			
			-55(+ 5-0)	-30	30			
				R, A (note 1)	+22 ±3	-15	15	
		+V _{CC} = 5V, -V _{CC} = Gnd, V _{CM} = +1.4V	+22 ±3	-10	10	nA		
			+125(+0-3)	-10	10			
			-55(+ 5-0)	-30	30			
				R, A (note 1)	+22 ±3	-15	15	
		+V _{CC} = 2.5V, -V _{CC} = -2.5, V _{CM} = -1.1V	+22 ±3	-10	10	nA		
			+125(+0-3)	-10	10			
			-55(+ 5-0)	-30	30			
				R, A (note 1)	+22 ±3	-15	15	

αRD124A Data Sheet

Electrical DC characteristics within operating temperature range

Table 3 (Continued)

Notes (1) (2)

Parameter	Symbol	Conditions	T _A , °C	Limits		Units	
				Min	Max		
Input Bias Current	±I _{IB}	+V _{CC} = 30V, -V _{CC} = Gnd, V _{CM} = +15V	+22 ±3	-50	0.1	nA	
			+125(+0-3)	-50	0.1		
			-55(+ 5-0)	-100	0.1		
			D, E, P, F, R (note 1)	+22 ±3	-75		0.1
			A (note 1)	+22 ±3	-130		0.1
				+22 ±3	-50		0.1
		+V _{CC} = 2V, -V _{CC} = -28V, V _{CM} = -13V	+22 ±3	-50	0.1	nA	
			+125(+0-3)	-50	0.1		
			-55(+ 5-0)	-100	0.1		
			D, E, P, F, R (note 1)	+22 ±3	-75		0.1
			A (note 1)	+22 ±3	-130		0.1
				+22 ±3	-50		0.1
		+V _{CC} = 5V, -V _{CC} = Gnd, V _{CM} = +1.4V	+22 ±3	-50	0.1	nA	
			+125(+0-3)	-50	0.1		
			-55(+ 5-0)	-100	0.1		
			D, E, P, F, R (note 1)	+22 ±3	-75		0.1
A (note 1)	+22 ±3		-130	0.1			
	+22 ±3		-50	0.1			
+V _{CC} = 2.5V, -V _{CC} = -2.5, V _{CM} = -1.1V	+22 ±3	-50	0.1	nA			
	+125(+0-3)	-50	0.1				
	-55(+ 5-0)	-100	0.1				
	D, E, P, F, R (note 1)	+22 ±3	-75		0.1		
	A (note 1)	+22 ±3	-130		0.1		
		+22 ±3	-50		0.1		
Power Supply Rejection Ratio	+PSRR	-V _{CC} = Gnd, V _{CM} = +1.4V, 5V ≤ V _{CC} ≤ 30V	+ 125°C ÷ -55°C	-100	100	μV/V	
Common Mode Rejection Ratio (note 3)	CMRR	+V _{CC} = 30V, -V _{CC} = Gnd, V _{CM} = 28.5V	+ 125°C ÷ -55°C	76	-	dB	
Short Circuit Output Current	I _{OS+}	+V _{CC} = 30V, -V _{CC} = Gnd, V _O = 25V	+ 125°C ÷ -55°C	-70	-	mA	
Power Supply Current	I _{CC}	+V _{CC} = 30V, -V _{CC} = Gnd, R _L = 10 kΩ	+22 ±3, +125(+0-3)	-	3	mA	
			-55(+ 5-0)	-	4		
			R, A (note 1)	+22 ±3	-		3
Low Level Output Voltage	V _{OL}	+V _{CC} = 30V, -V _{CC} = Gnd, R _L = 10kΩ	+ 125°C ÷ -55°C			mV	
		R, A (note 1)	+22 ±3	-	35		
		+V _{CC} = 30V, -V _{CC} = Gnd, I _{OL} = 5mA	+ 125°C ÷ -55°C	-	1.5		V
High Level Output Voltage	V _{OH}	+V _{CC} = 30V, -V _{CC} = Gnd, I _{OH} = -10mA	+ 125°C ÷ -55°C			V	
		R, A (note 1)	+22 ±3	27	-		
		+V _{CC} = 4.5V, -V _{CC} = Gnd, I _{OH} = -10mA	+ 125°C ÷ -55°C	2.4	-		V
Open Loop Voltage Gain (Plus)	+AVS	+V _{CC} = 30V, -V _{CC} = Gnd, 1V ≤ V _O ≤ 26V, R _L = 10kΩ	+22 ±3	50	-	V/mV	
			+125(+0-3), -55(+ 5-0)	25	-		
			R, A (note 1)	+22 ±3	40		-
		V _{CC} = 30V, -V _{CC} = Gnd, 5V ≤ V _O ≤ 20V, R _L = 2kΩ	+22 ±3	50	-	V/mV	
			+125(+0-3), -55(+ 5-0)	25	-		
			R, A (note 1)	+22 ±3	40		-

αRD124A Data Sheet

Electrical DC characteristics within operating temperature range

Table 3 (Continued)

Notes (1) (2)

Parameter	Symbol	Conditions	T _A , °C	Limits		Units
				Min	Max	
Open Loop Voltage Gain	AVS	+V _{CC} = 5V, -V _{CC} = Gnd, 1V ≤ V _O ≤ 2.5V, R _L = 10kΩ	+ 125°C ÷ -55°C	10	-	V/mV
		+V _{CC} = 5V, -V _{CC} = Gnd, 1V ≤ V _O ≤ 2.5V, R _L = 2kΩ	+ 125°C ÷ -55°C	10	-	V/mV
Output Voltage Swing (Plus)	V _{OUT} (+)	+V _{CC} = 30V, -V _{CC} = Gnd, V _O = +30V, R _L = 10kΩ	+ 125°C ÷ -55°C	27	-	V
		+V _{CC} = 30V, -V _{CC} = Gnd, V _O = +30V, R _L = 2kΩ	+ 125°C ÷ -55°C	26	-	V
Input Offset Voltage Temperature Sensitivity (note 4)	ΔV _{IO} / ΔT	+V _{CC} = 5V, -V _{CC} = 0V, V _{CM} = +1.4V	-55°C ≤ T _A ≤ +25°C	-30	30	μV/°C
Input Offset Current Temperature Sensitivity (note 4)	ΔI _{IO} / ΔT	+V _{CC} = 5V, -V _{CC} = 0V, V _{CM} = +1.4V	-55°C ≤ T _A ≤ +25°C	-700	700	pA/°C
Input Offset Voltage Temperature Sensitivity (note 4)	ΔV _{IO} / ΔT	+V _{CC} = 5V, -V _{CC} = 0V, V _{CM} = +1.4V	+25°C ≤ T _A ≤ +125°C	-30	30	μV/°C
Input Offset Current Temperature Sensitivity (note 4)	ΔI _{IO} / ΔT	+V _{CC} = 5V, -V _{CC} = 0V, V _{CM} = +1.4V	+25°C ≤ T _A ≤ +125°C	-400	400	pA/°C

Electrical AC characteristics within operating temperature range

Table 4

Notes (1) (2)

Parameter	Symbol	Test Conditions	T _A , °C	Limits		Units
				Min	Max	
Rise Time	Tr	+V _{CC} = 30V, -V _{CC} = Gnd, V _{outAC} = -200mV, V _{outDC} = +600mV, A _{CL} =+1, R _L =2 kΩ, C _L =50pF	+ 125°C ÷ -55°C	-	1	μs
Overshoot	OS	+V _{CC} = 30V, -V _{CC} = Gnd, U _{out} =(0V ÷ + 10V), A _{CL} =+1, R _L =2 kΩ, C _L =50pF	+ 125°C ÷ -55°C	-	50	%
Slew Rate (Plus)	SR(+)	+V _{CC} = 30V, -V _{CC} = Gnd, U _{out} =(0V ÷ + 10V), A _{CL} =+1, R _L =2 kΩ, C _L =50pF	+ 125°C ÷ -55°C	0.1	-	V/μs
			R, A (note 1)			
Slew Rate (Minus)	SR(-)	+V _{CC} = 30V, -V _{CC} = Gnd, U _{out} =(0V ÷ + 10V), A _{CL} =+1, R _L =2 kΩ, C _L =50pF	+ 125°C ÷ -55°C	0.1	-	V/μs
			R, A (note 1)			
Noise Broadband	NIBB	+V _{CC} = 15V, -V _{CC} = -15V, BW = 10Hz to 5kHz	+22 ±3	-	15	μV _{rms}
Noise Popcorn	NIPC	+V _{CC} = 15V, -V _{CC} = -15V, R _S = 20kΩ, BW = 10Hz to 5kHz	+22 ±3	-	50	μV _{pK}
Channel Separation (note 5)	Cs	+V _{CC} = 30V, -V _{CC} = Gnd, R _L = 2kΩ, V _{IN} = 1V and 16V	+22 ±3	80	-	dB

Notes: (1) Post irradiation limits are identical to those listed under AC and DC electrical characteristics except as listed in the line denoted “D, E, P, F, R and A” (correspond to 10, 20, 30, 50, 100 and 300 krads (Si) respectively) of “Conditions” section Table 3(a). Instead of RHA designator “A” can be used RHA designator “F” (correspond to 300 krads (Si) in accordance of MIL-PRF-38535).

Radiation end point limits for the noted parameters are ensured only for the conditions as specified in ESCC 22900.

α RD124A Data Sheet

- (2) Low dose rate testing should be performed on a wafer-by-wafer basis, per ESCC 22900 p.5.2, with no enhanced low dose rate sensitivity (ELDRS) effect.
- (3) The input common mode voltage of either input signal voltage should not be allowed to go negative by more than 0.3 V. The upper end of the common mode voltage range is $V^+ - 1.5$ V (at $+22 \pm 3$) but either or both inputs can go to +30 V dc without damage independent of the magnitude of V^+ .
- (4) Calculated parameters
- (5) Due to proximity of external components, ensure that coupling is not originating via stray capacitance between these external parts. This typically can be detected as this type of capacitance increases at higher frequencies.

Physical Dimensions

Figure 3

14 LEAD FLAT PKG

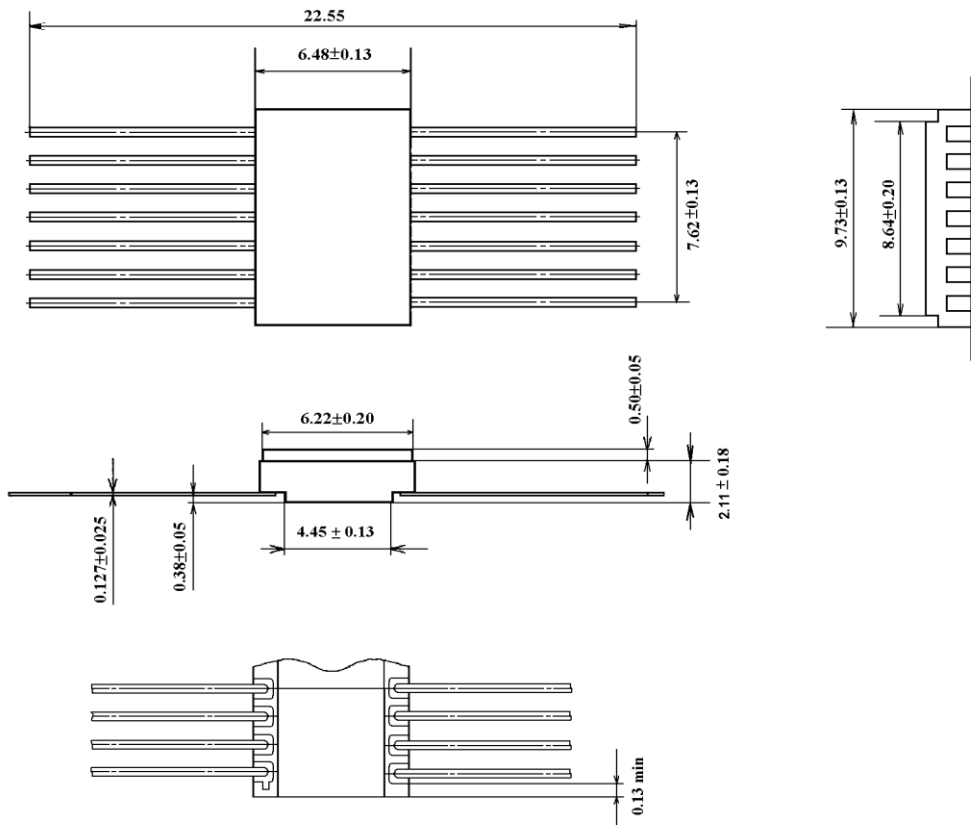

αRD124A Data Sheet

All RD ALFA Microelectronics semiconductor products are manufactured, assembled and tested under ISO9001 quality systems certification.

RD ALFA Microelectronics products are sold by description only. RD ALFA Microelectronics reserves the right to make changes in circuit design and/or specifications at any time without notice. Accordingly, the reader is cautioned to verify that data sheets are current before placing orders. Information furnished by RD ALFA Microelectronics is believed to be accurate and reliable. However, no responsibility is assumed by RD ALFA Microelectronics or its subsidiaries for its use; nor for any infringements of patents or other rights of third parties which may result from its use. No license is granted by implication or otherwise under any patent or patent rights of RD ALFA Microelectronics or its subsidiaries.

For information regarding RD ALFA Microelectronics and its products, see web site <http://www.rdalfa.eu>